

C3000 Pump

Pump Type	Positive displacement syringe pump
Drive Design	Stepper motor/leadscrew with 30mm of travel. Manually moveable for “power off” syringe removal. Proprietary maintenance-free design.
Speed	1.2 seconds to 20 minutes
Step Resolution	Standard mode 3,000 steps, Hi-Res mode 24,000 steps
Imprecision (full stroke)	≤0.1% CV @ 50 L to 100 L ≤0.05% CV @ 250 L to 5mL
Inaccuracy (full stroke)	≤1% syringe volume
Dimensions	1.75” W x 5.00” H x 4.50” D 44.5cm x 127mm x 114.3mm
Available Volumes	50 L, 100 L, 250 L, 500 L, 1mL, 2.5mL, 5mL
Valve Drive	Stepper motor with position sensors. ≤ 250ms between neighboring ports
Power Requirement	24 VDC +/-10%
Power Rating	≥ 1.5 Amp (peak)
Fluid Contact Components	Syringe – Borosilicate Glass and UHMWPE or PTFE (seal) – Pressures to 80 PSI Valve – PEEK (body) and UHMWPE (plug) – Pressures to 100 PSI
Interface	
Type	RS-232, RS-485 or CAN
Communication Rates	9600 or 38400 (RS-232, RS-485) 100K or 125K (CAN)
Format (RS-232/485)	Data Bits – 8, Parity – None, Stop Bit – 1 Half Duplex, Data Terminal and OEM protocols
Addressing	Maximum of 15 pumps addressed individually
Environmental (Operating)	
Temperature	15 C to 40 C (59 F to 104 F)
Humidity	20-95%RH @ 40 C (104 F)
Regulatory Compliance	TriContinent operates a manufacturing facility with an ISO 13485 compliant quality system. The C3000 is a general laboratory module not subject to FDA regulatory approval. UL approved components are used wherever possible. The C3000 does not carry an independent CE mark as it is a component designed for use within larger systems, which are subject to independent testing and certification.

TriContinent, Inc.

12555 Loma Rica Drive Grass Valley, California 95945

Tel: (800) We-Pipet or (530) 273-2586 Fax: (530)273-2586

Email: liquidhandling@tricontinent.com Web: www.tricontinent.com

ENVELOPE AND MOUNTING DRAWING

ALL MOUNTING HOLES ARE
M3 X .5mm X 6.3mm DEEP MIN.

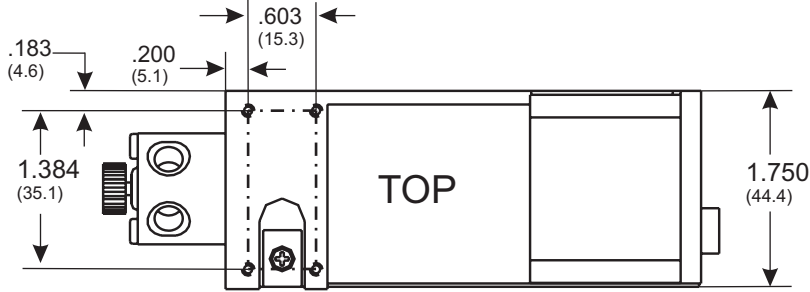

ALL MOUNTING HOLES ARE
M3 X .5mm X 6.3 DEEP MIN.

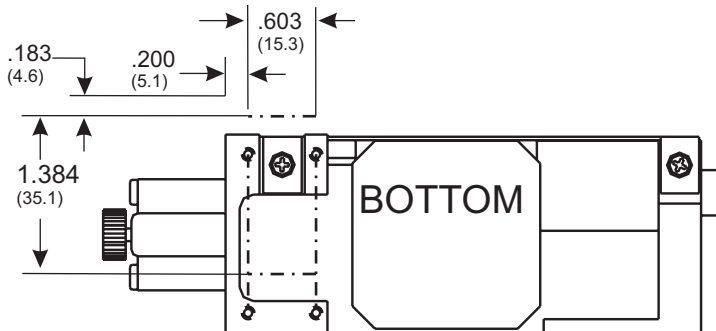
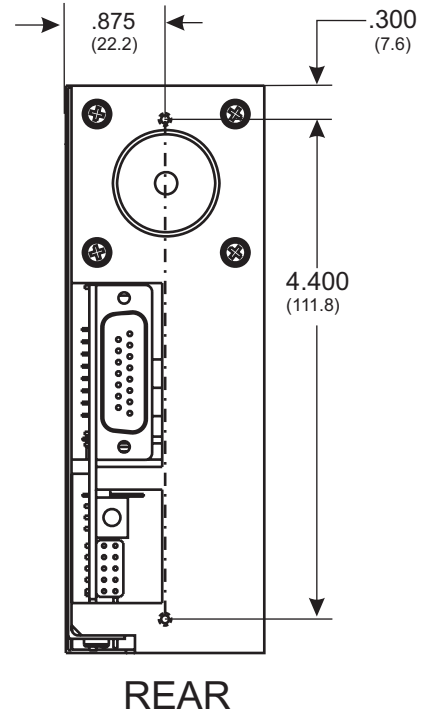
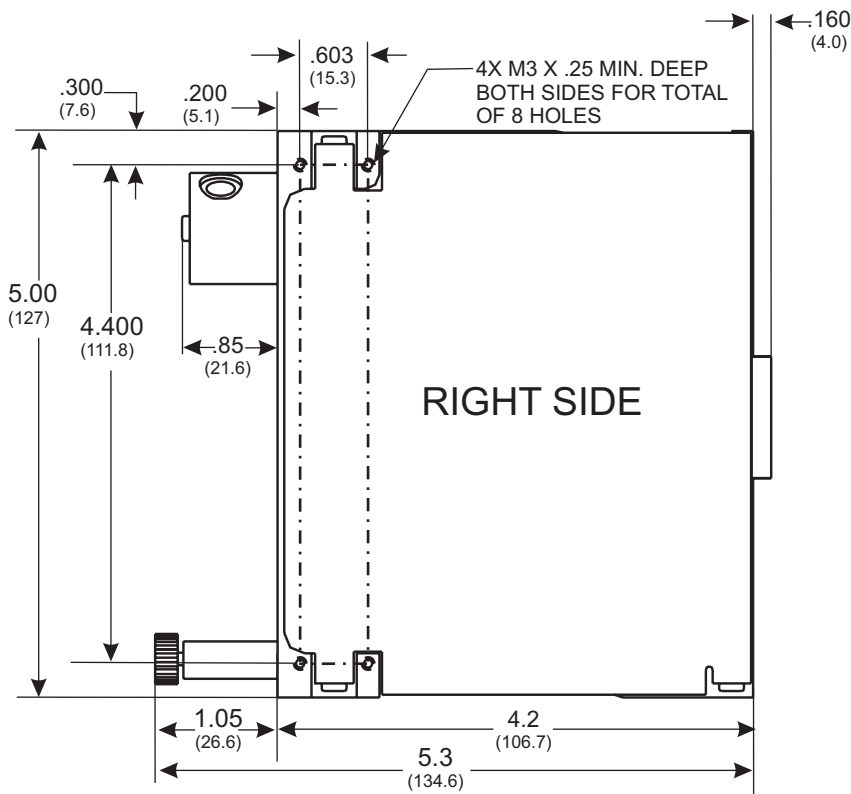

ALL DIMENSIONS UNLESS
OTHERWISE SPECIFIED
.XXX ± .008 (.02mm)
(MILLIMETERS SHOWN IN BRACKETS)